

Series PM

Incremental hollow shaft encoder, panted self-aligning system

Mechanics Data

Cover:	Aluminium
Body:	Aluminium
Solid shaft:	Stainless steel
Bearings:	2, ballraces
Weight:	Approx.800gr.
Protection:	IP55
Rpm:	3000 Max
Torque:	3,5Ncm
Inertia:	60gcm ²
Shaft loading MAX:	Axial 50N - Radial 50N
Recovery max value:	Angular 1,5° -0,7mm axial and radial



Dimensions mm.

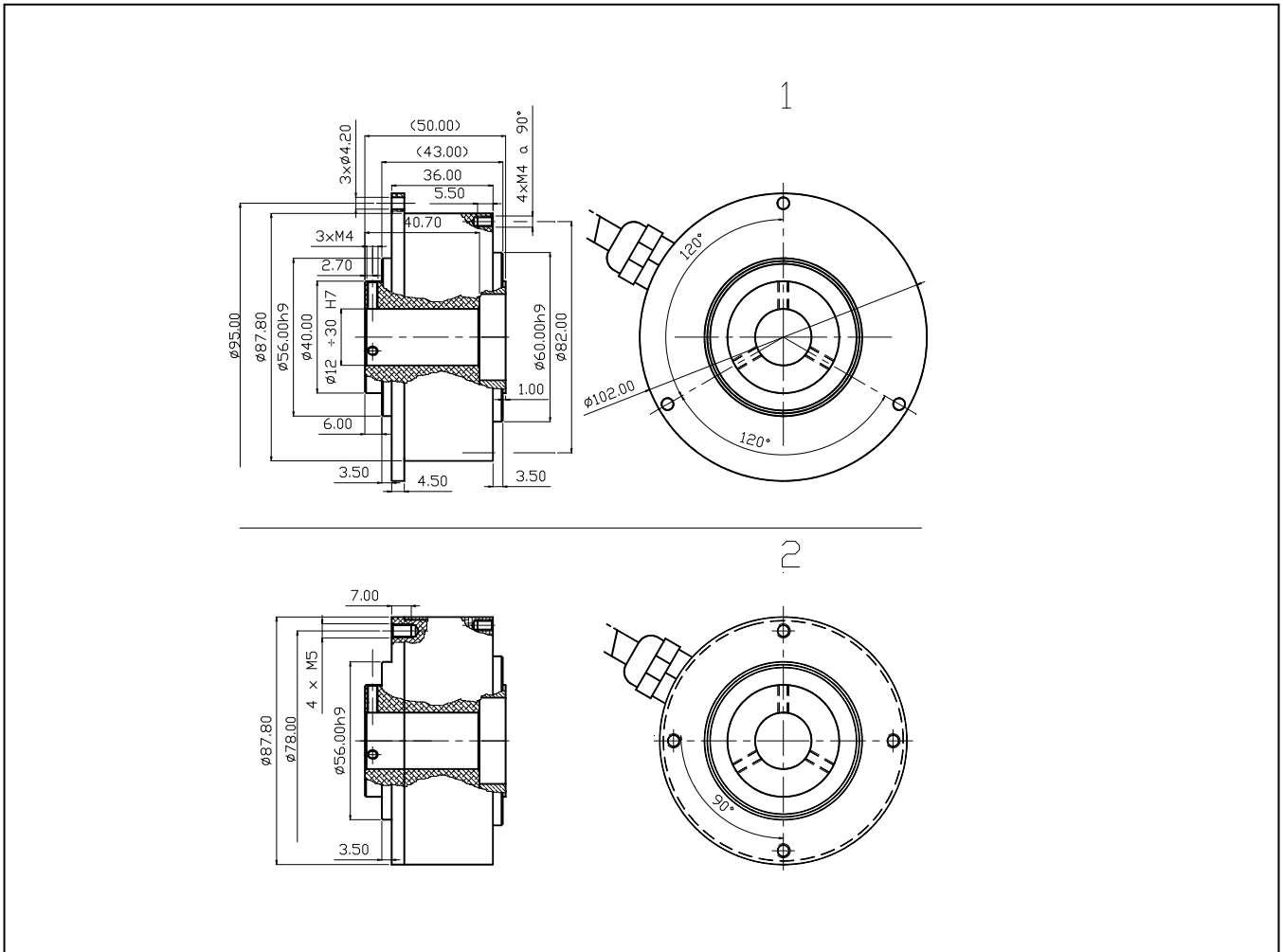

Series PM

Electronics Data

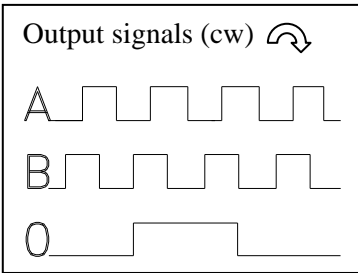

Power supply: from 5 to 24V depends on the electronics circuit
 Current consumption: 40/80mA depends on the electronics circuit
 Permissible load: 20/40mA depends on the electronics circuit
 Frequency: 100KHz
 Protections: Against short circuit, reversal polarity
 Operating Temp.: -10/+60°C

Ordering code

Series **P M** - *** * * * *** / **Pulses** (Max 3600)

Shaft

15 = Ø15mm
 20 = Ø20mm
 25 = Ø25,4mm
 30 = Ø30mm
 On request other Ø

Flange

1 = See previous
 2 = page

Outputs

P = AB0+ $\overline{AB0}$ PP11/28V
 C = AB0 OC11/28V
 H = AB0 NPN 11/28V
 6 = AB0+ $\overline{AB0}$ LD5V
 9 = AB0+ $\overline{AB0}$ LD5/12V
 T = AB0+ $\overline{AB0}$ LD15/24V
 (out 12V - 20mA channel)
 K = AB0+ $\overline{AB0}$ LD15/24
 (out 5V - 20mA channel)

Connections

1 = 9415 Radial
 3 = Cable Radial
 5 = 9416 Radial

Options

0 = None
 Z = Synchronised zero pulse to 180° only for Line Driver
 W = Synchronised zero pulse to 90° only for Line Driver
 A = Special connections
 U = Power supply 5/30V outputs PP

Option U: outputs levels compatible TTL · Low level output < 0.5V · High level output > +VCC-1,9V

Connections

	0 Volt	+ Volt	A	B	\overline{A}	\overline{B}	0	$\overline{0}$
Cable 5 Pole	White	Brown	Green	Yellow			Gray	
Cable 8 pole	Black	Blue	Brown	Beige	Green	Yellow	Pink	Violet
Connector 9416-9415	Pin1	Pin2	Pin3	Pin4	Pin5	Pin6	Pin7	Pin8